

# Performances of a Date Dissemination Code on Telephone Lines Using Commercial Modems

F. Cordara, V. Pettiti,  
Istituto Elettrotecnico Nazionale  
Galileo Ferraris  
c.so Massimo D'Azeglio no. 42  
I-10125 Torino, Italy

R. Quasso, E. Rubiola  
Politecnico di Torino  
Dipartimento di Elettronica  
c.so Duca degli Abruzzi no. 24  
I-10129 Torino, Italy

## Abstract

*A coded time/date information dissemination system (CTD), based on telephone lines and commercial modems, is now in its experimental phase in Italy at IEN. This service, born from a cooperation with other metrological laboratories (TUG, Austria, SNT, Sweden, VSL, The Netherlands), represents an attempt towards an European standardization.*

*This paper will give some results of an experimental analysis in which a few modems have been tested, both in laboratory conditions and connected to the telephone network, in order to evaluate the timing capability of the system.*

*When the system is used in a one-way mode, in many practical cases the modems delay turns out to be the main factor which limits the accuracy, even more than the telephone line delays. If the two-way mode is used, the modems asymmetry, i.e., the delay difference between transmission and reception, is almost always the most important source of uncertainty, provided the link is not including a space segment.*

*Comparing the widely used V.22 modems to the old V.21 ones, the latter turn out to be better both in delay time (30–100 ms V.22, and 7–15 ms V.21) and asymmetry (10–50  $\mu$ s V.21, and 10 ms V.22).*

*Time transfer accuracies of 10  $\mu$ s (same town) to 100  $\mu$ s (long distance calls) have been obtained in two-way mode with commercial V.21 modems.*

## 1 Introduction

In 1991, four European time and frequency laboratories, namely IEN, SNT, TUG and VSL, that perform standard time dissemination in Italy, Sweden, Austria and the Netherlands respectively, agreed upon a format for the distribution of a coded date and time information on telephone lines using commercial modems [1].

This dissemination service, designed to synchronize computer clocks or digital terminals, is capable to attain accuracies ranging from low to medium (100 ms to 1 ms), as reported in previous papers dealing with similar synchronization systems realized in Canada [2] and in the USA [3].

1	10	20	30	40	50	60	70	78	80
---	----	----	----	----	----	----	----	----	----

```

1992-11-13 08:53:55 CET 54631800000019921113075348939+3+00000 I.E.N. TORINO *<LF>
|   |   |   |   |   |   |   |   |   |   |   |   |   |   |   |   |   |   |   |
A   B   C   D   E   F   G   H I J K L M N O P Q R S   T U V W           X Y

```

←----- LOCAL TIME ----->
←----- UTC TIME ----->
←----- OTHER INFORMATION ----->

**LOCAL TIME INFORMATION**

- A year
- B month
- C day
- D hour
- E minute
- F second
- G local time identifier  
CET (Central Europe Time)  
CEST (Central Europe Summer Time)
- H day of the week
- I week of the year
- J day of the year
- K month of the next change from CET to CEST or viceversa
- L day of the next change from CET to CEST or viceversa
- M hour of the next change from CET to CEST or viceversa

**UTC INFORMATION**

- N year
- O month
- P day
- Q hour
- R minute
- S Modified Julian Date (MJD)
- T DUT1: time difference, in tenth of seconds, between UT1 and UTC time scales
- U month of the next leap second; contains also the sign (+/-)

**OTHER INFORMATION**

- V propagation time compensation (in millisecond), if not performed the digits are: 000
- W message (15 characters)
- X visible time marker: can change to "\*" when advanced to compensate for the propagation delay
- Y electrical time marker, CR/LF sequence  
(CR = Carriage Return, LF = Line Feed)

Figure 1: CTD format and features.

The Istituto Elettrotecnico Nazionale (IEN), which is responsible for the national time scale in Italy, has implemented since mid 1991 this coded time information for telephone lines (CTD) that is presently accessible dialling number (+39) 11 3487892.

It has been demonstrated that the delays introduced by telephone lines are very stable compared to those due to the telephone network equipment, and that the modems used both at the code generation side and at the users end are by far the most influential factor in the synchronization error of these services.

To evaluate the accuracy achievable by using this code in the Italian telephone network, special care has been therefore devoted to modems delays and their asymmetries. The network behaviour has also been tested performing round-trip delay measurements both for in-town and long distance calls.

Modems of different CCITT standard (V.21 and V.22) and manufacturer have been tested using as reference signals both the CTD timing reference and ASCII characters generated by a personal computer.

The following sections describe in details the format of the CTD and its realization, the measurement setup used, the results obtained in the delay measurements of the modems and of the telephone line and some consideration about the accuracies that could be obtained by users of CTD in the field of time and frequency.

## 2 The coded date information for telephone lines

The European code, implemented at IEN and operative also in Austria [4] and Sweden [5], consists of a 80 ASCII characters line transmitted each second, supplying the date, the time and some information relative to the corrections performed on the legal time or special warnings regarding time scales.

The code format and access protocol have been agreed so as to allow a user terminal to connect via a CCITT V.22 modem configured for 1200 bit/s, 8 bits, 1 stop bit, no parity, and the time information transmitted is relative to the incoming second. The reference of time is given by the last three characters, namely "\*", Carriage Return (CR) and Line Feed (LF). The leading edge between the stop bit of CR and the start bit of LF is "on time" with the UTC(IEN) second. This reference point can be advanced to compensate for the transmission delay if this feature is implemented.

A sample of one line of the code as generated at IEN with full details is shown in Fig. 1.

The characters from 1 to 37, identified in Fig. 1 by letters from A to M, give the date and time information in Italian legal time, meanwhile those from 38 to 59 (letters N to U) supply the time information according to the UTC time scale together with the Modified Julian Date and the DUT1 difference between UT1 and UTC time scales.

It can be noticed that the format of the timing sequence has been chosen so as to leave the first 24 characters, giving the date and time, easily readable. Concerning the characters from 60 to 77 (letters V and W), the first three give the amount of the propagation delay compensated by advancing the time marker, and fifteen can be used for messages.

Finally, character no. 78, "\*", is changed in "#" if the delay compensation is performed by the generator side.

The duration of a character is 833  $\mu$ s and the beginning of the time code string occurs 50 ms after the UTC(IEN) second. The timing of the last three characters of the string can vary to compensate for a maximum delay of about 0.3 seconds.

The block diagram of the CTD generator is shown in Fig. 2.

Two standard frequencies from IEN cesium clocks are supplied to the device to phase-lock its internal 10 MHz clock oscillator that is used as time base for the microprocessor unit generating the time code string. The clock functions can be checked and updated by a keyboard or a PC interface.

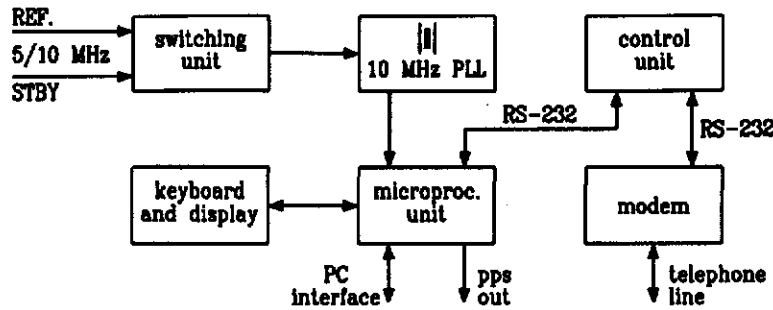

Figure 2: CTD generator block diagram.

The output signal, available on an RS-232 interface, is synchronized to UTC(IEN) within  $0.2 \mu\text{s}$  and sent to a control unit and succeeding to the modem input. The control unit checks the user's connection time, presently limited to one minute, and allows for counting the daily number of calls and their distribution in time.

The 1200 bit/s rate at the CTD/RS-232 interface, is synchronized with the reference time base and the time marker jitter is below  $1 \mu\text{s}$ .

The definitive generation scheme, that will be ready for the beginning of 1993, will rely upon three devices and a switching unit to check the time code sent to the telephone line.

### 3 Experimental methods and equipment

When using the classical one-way scheme in telephone network synchronization, we define the propagation time  $t_p$  between laboratory  $A$  (source) and  $B$  (user) as

$$t_p = t_a + t_l + t_b \quad (1)$$

where  $t_a$  and  $t_b$  are modem delays (laboratories  $A$  and  $B$  respectively) and  $t_l$  is the line delay, as seen at the telephone twisted pairs extremes.

In the two-ways scheme, the propagation time  $\bar{t}_p$  from  $A$  to  $B$  is estimated as half the echo time

$$\bar{t}_p = \frac{1}{2} (t'_p + t''_p) \quad (2)$$

where  $t'_p$  and  $t''_p$  are the path delays from  $A$  to  $B$  and from  $B$  to  $A$  respectively.

The residual error is

$$\epsilon = \frac{1}{2} (t'_a - t''_a) + \frac{1}{2} (t'_l - t''_l) + \frac{1}{2} (t'_b - t''_b) \quad (3)$$

where the terms in brackets highlight asymmetry contributions of each element, either line or modem.

Unfortunately,  $t_a$  and  $t_b$  are hardly measurable separately because there are no suitable time markers on the signal; there are modulated waveforms only, with a given duration and bandwidth. Moreover, any attempt to measure these delays seems somewhat misleading because the modem front-end interacts with the line; this interaction involves bandwidth, impedance matching and equalization. Hence the sum  $t_a + t_b$  was measured as a single quantity.

The basic scheme adopted in all measurements is shown in Fig. 3, where an arming circuit, not shown, ensures that start and stop events are related to the same edge. In a first set of measurements the line (dashed box in the scheme) was simulated by attenuating the signal by 10 dB, which is the

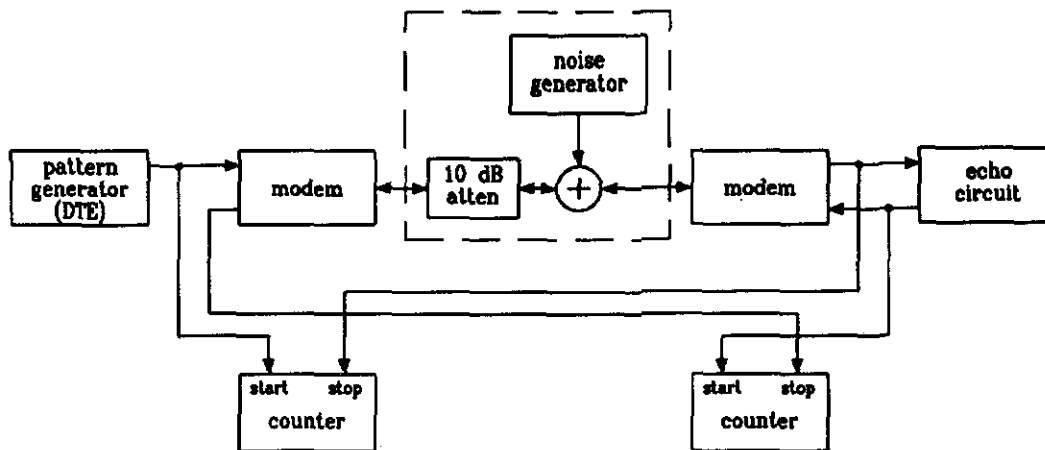

Figure 3: Experimental setup.

factory and type		standard	analog or digital	no. available devices
AET	MD 300	V.21 only	analog	2
AET	2.4 Must	V.21 / V.22	digital	1
Dataconsyst		V.21 / V.22	digital	1
Hyundai	MD 2404	V.21 / V.22	digital	2
Smartlink	1200 S	V.21 / V.22	digital	1

Table 1: Modems under test.

typical line loss [6], and adding noise. Later on, a line simulator (passive RC network) and a true line were used.

Three test patterns were adopted: (i) a stream of "U" characters, which appears as a squarewave on the RS-232 interface, giving the maximum number of measurements per second, (ii) a stream of NUL characters (ASCII 0), which is a sequence of pulses (start bits), and (iii) the CTD.

Experiments were performed with some modems (Table 1), available both at the Politecnico and at the IEN. These equipment are representative of the low speed class of modems. High speed modems were not considered because they often use sophisticated coding and buffering techniques which make time delay more unpredictable.

Time delays were averaged on suitable block sizes, say 5000, in order to keep the noise effect at a negligible level.

Time jitter  $\sigma$  was measured as the standard deviation of the average values of blocks; its value depend on the block size  $n$ . Allan variance was not considered because no diverging process is involved in our experiments.

## 4 Modem measurements

### 4.1 CCITT standard V.22

These equipment work at 1200 bit/s with Q-PSK (quad phase shift keying) modulation. Their internal circuits are often based on sampling processes and digital hardware. Bits are packed in dibit (2 bits)

symbols after a scrambling process [7] defined by

$$B = S_0 \oplus S_{-14} \oplus S_{-17} \quad (4)$$

where  $B$  is the current output bit,  $S_0$  is the current source bit,  $S_{-i}$  the  $i^{\text{th}}$  previous one and  $\oplus$  means ex-or. The duration of 18 bits is needed for the complete scrambling process. Since unscrambling needs the same time, the complete scrambling/unscrambling operation takes 36 bits time, which lasts 30 ms. This is the lower bound for  $t_a + t_b$ . Additional delays are due to modulation/demodulation, filtering, impedance equalization. Some equipment are capable of adaptive equalization during the communication, others have a complex buffering mechanism. Both of these features, not present in our measurements, could affect time jitter and repeatability.

When the modems, working in full duplex asynchronous mode, were connected via a 10 dB attenuator, the following averaged time delays for two couples of equipment were measured using 5000 samples.

couple	$t'_a + t'_b$	$t''_a + t''_b$	asimmetry error
			$ (t'_a + t'_b) - (t''_a + t''_b) /2$
no. 1	46.6 ms	31.6 ms	7.5 ms
no. 2	34.0 ms	58.7 ms	12.35 ms

#### 4.1.1 Time jitter and related problems

In a V.22 asynchronous communication only the DTE/modem connections are actually asynchronous, while the two modems are synchronized each other by means of the data flow. Focusing our attention on the transmitting side (source DTE and modem) we observe that the data rate is driven by the DTE on the DTE/modem connection, and by the modem on the telephone line. Since each equipment works under control of its internal quartz oscillator, stuffing idle bits are added or removed in order to ensure the same data flow for the two devices.

The main consequence of this is that the term  $(t_a + t_b)$  shows a sawtooth behaviour whose period  $T_{\text{beat}}$  is related to the DTE and modem oscillators relative frequency offsets, and whose peak-to-peak value is the duration  $T_s$  of one bit (833  $\mu\text{s}$  at 1200 bit/s). This sawtooth behaviour has been observed in all the modems considered;  $T_{\text{beat}}$  fits exactly to its calculated value, which is based on the measurements of the DTE and modem oscillators offsets. Moreover, changing the frequency of an oscillator we got different  $T_{\text{beat}}$  in agreement with the foreseen values.

The beat phenomenon gives to the time jitter a contribution similar to a random variable uniformly distributed between  $\pm T_s/2$ , whose standard deviation is  $\sigma_{\text{beat}} = T_s/(2\sqrt{3}) \simeq 240 \mu\text{s}$ . When measuring time jitter, we expect that the contribution of  $\sigma_{\text{beat}}$  is flat (slope 0) for observation time (i.e., the time needed for acquiring one data block)  $\tau \leq T_{\text{beat}}$ , and that is reduced a factor  $1/n$  (slope -1) for  $\tau \gg T_{\text{beat}}$ .

The experimental results, shown in Fig. 4A (plot  $\square$ ), are in agreement to the foreseen behaviour. Since  $\sigma \simeq 240 \mu\text{s}$  for small  $\tau$ , any "true" noise phenomena seem to give a contribution that is negligible when compared to the beat effect. Changing the data flow rate, plots similar to that shown in Fig. 4A (plot  $\square$ ) were obtained, but the cross point between slopes 0 and -1 occurred for the same  $\tau$  — with different values of  $n$  — because it depends on  $\tau$  only.

When modems are synchronously connected to the DTE, the effect of oscillators offset vanishes. Variations of 30–80  $\mu\text{s}$  peak-to-peak are still present on  $t_a + t_b$ , probably due to modulation/demodulation processes. Figure 4A (plot  $\triangle$ ) shows typical experimental jitter values.

Finally, the effect of the telephone line noise was simulated by injecting white noise into the modem/modem connection. Figure 4B shows typical results measured in extreme conditions,  $S/N = 8 \text{ dB}$

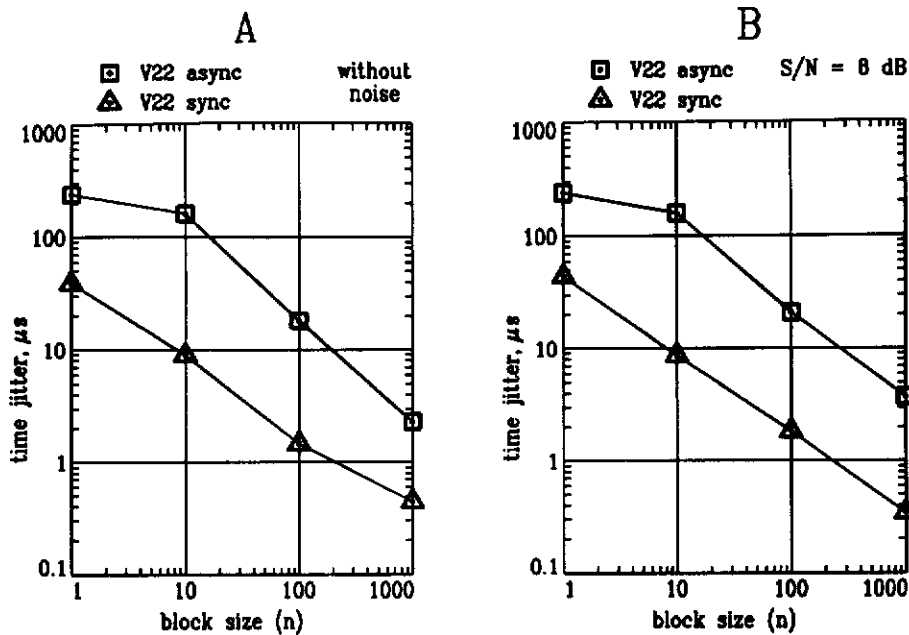

Figure 4: Typical time jitter measured sending 3 NUL characters per second on a V.22 modems connection.

in the 300–3400 Hz band, for both asynchronous and synchronous connections. When V.22 modems operate synchronously, the plot overlaps almost exactly to the previous one, measured without noise. When the asynchronous mode is chosen, a small noise contribution to the time jitter appears for  $n = 100$  to  $n = 1000$ .

#### 4.2 CCITT standard V.21

In this standard, almost in disuse, information is sent at 300 bit/s in FSK (frequency shift keying). Since frequency modulation is directly driven by the source bits, the DTE/modem connection is, in principle, synchronous.

Because of different behaviours observed for timing applications, we divided the V.21 equipment in two categories, based on internal circuits type. Thus we name *analog* the oldest equipment, based on fully analog circuits, and *digital* the new ones, which are actually V.22 modems set in the V.21 mode. The last ones often include digital waveform synthesis and sampling.

Digital modems connections delay show a sawtooth behaviour similar to what observed in the V.22 ones. However, peak-to-peak delay variations are about 300 μs, which is far less than the bit duration of 3.3 ms. This behaviour is supposed to be due to a difference in relative frequency offset between modem and DTE, which is compensated by steps by the modem synthesizer. This statement is supported by the fact that  $T_{beat}$  is properly related to these frequency offsets.

Analog modem were found to be free from any beat phenomena.

Figure 5A shows the typical  $t_a + t_b$  jitter for couples of analog and digital modems connected through the 10 dB attenuator.

The effect of the noise, tested in the same conditions as for V.22 modems, is shown in Fig. 5B; these results are to be compared to those measured without noise (Fig. 5A). Injected noise (S/N = 8 dB) increases the jitter nearly by a factor three in digital modems, while the analog equipment show

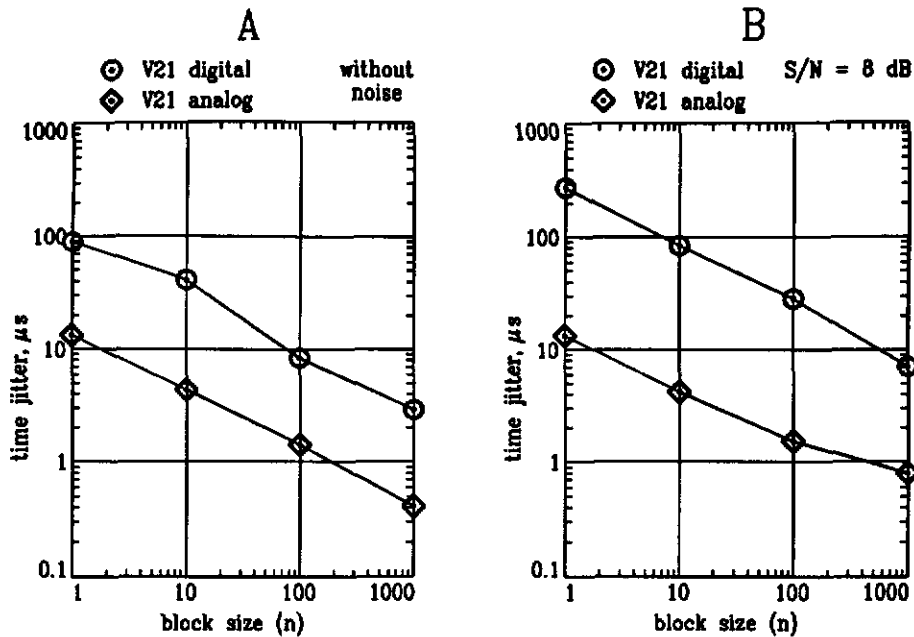

Figure 5: Typical time jitter measured sending 3 NUL characters per second on a V.21 modems connection.

a small difference for large  $n$  only. When connecting analog modems through a local loop — i.e., two links from IEN to the same telephone switch, some kilometers apart — jitter resulted to be higher by a factor 1.5 compared to that measured in absence of noise.

As regards to delay and simmetry, the following values were measured.

type	$t'_a + t'_b$	$t''_a + t''_b$	asimmetry error $ (t'_a + t'_b) - (t''_a + t''_b) /2$
†digital	12.55 ms	12.48 ms	35 $\mu$ s
†analog	6.889 ms	6.990 ms	50 $\mu$ s
‡analog	6.889 ms	6.869 ms	10 $\mu$ s
† full duplex	‡ half duplex like connection		

Results shown in the first two rows of the table can be compared directly because both digital and analog couples of modem were measured in full duplex mode. Analog modems were also tested (3rd row) exchanging the calling and answering role, thus keeping the same frequency modulation for the two directions; this is roughly equivalent to a half duplex connection.

## 5 Telephone line measurements

Cables have a remarkable potential in time transfer, as it was shown in past works using a dedicate coaxial cable (accuracy of some microseconds at 700 km distance [8]) and a dedicate telephone twisted pair (stability of 10 ns at 10 km [9]). Conversely, a telephone network, although based on cables and amplifiers symilar to those of dedicated links, gives additional problems due to FDM (frequency division multiplexing) or TDM (time division multiplexing) equipment, switches and other devices.



cable or equipment type	delay
coax cable under ground	4 ns/m
FDM modulation or demodulation	750 $\mu$ s
PCM coding or decoding	300 $\mu$ s
digital exchange (connection)	450 $\mu$ s
digital exchange (ending)	800 $\mu$ s
for each analog interface add	300 $\mu$ s

Table 2: Typical delays of the Italian telephone network.

Table 2, taken from [6] gives the typical delays for the Italian network. Unfortunately, information on the network configuration and signal paths are not available in most cases. Comparing a rough estimate of path delays, based on the geographic distance, to modem delays, these last ones turn out to be far bigger; consequently, it was decided to measure the connection in some cases.

All experiments were done with two analog V.21 modems carefully calibrated in order to evaluate the delay due to the line only. In spite of this, it has been impossible to separate modem and line contributions to the measurement instabilities.

A first set of measurements was done at the IEN, using the local loop. An average delay  $t_l = 219 \mu$ s was measured in half duplex mode, with small variations — less than 5  $\mu$ s peak-to-peak — during the same call. Exchanging the two modems, but keeping the same modulation frequencies, line asymmetry was always less than 5  $\mu$ s, which implies a maximum contribution of 2.5  $\mu$ s to the two-ways synchronization error  $\epsilon$ . When hanging up and redialling,  $t_l$  showed slight changes, with a standard deviation between calls of 7.5  $\mu$ s (carrier 1750 Hz) and 20  $\mu$ s (carrier 1080 Hz).

A more significant asymmetry ( $t'_l = 219 \mu$ s and  $t''_l = 356 \mu$ s) arose when modems were set in full duplex mode. This is due to the line response to the different carriers used for the two directions.

In a second experiment, we measured the link between IEN and a calibration laboratory in Milano (SIRTI), whose distance is about 130 km, using the same couple of modems in half duplex. Path delay was  $t_l \simeq 4$  ms, stable within  $\pm 200 \mu$ s when hanging up and redialling. Line asymmetry error was between 25 and 75  $\mu$ s, depending on the time of the day, and consequently on the telephone traffic on the network.

timing error	modem type	distance call	sync. method
30-120 ms	V.22	long	one way
30-100 ms	V.22	short	
7-30 ms	V.21	long	
7-14 ms	V.21	short	
10 ms	V.22	long/short	two ways
200 $\mu$ s	V.21 digital	long	
100 $\mu$ s	V.21 digital	short	
100 $\mu$ s	V.21 analog	long	
10 $\mu$ s	V.21 analog	short	

Table 3: Time transfer errors.

## 6 Conclusions

Timing accuracies, taken from the last two sections, are combined in Table 3. It has been assumed that no propagation estimate is used in one-way mode, and no care is taken about symmetry for two-ways mode.

The CTD service, as presently implemented (one-way, using 1200 bit/s V.22 modems), ensures timing accuracies of 100–120 ms. A correction, based only on the lower bound of the modems delay and made either by the IEN or by the user, reduces the error to 70–90 ms.

When the system is used for frequency calibration, timing accuracy is replaced by repeatability in the errors budget. Taking two averaged time values over one day, frequency accuracies from some units  $10^{-9}$  to  $10^{-10}$  can be expected.

A two-ways extension of the CTD service is under study. A timing accuracy of 10 ms is achievable without calibrating modem asymmetries. It seems that an improvement by a factor 10 can be obtained if the nominal asymmetry of the user's modem type (factory and model) is specified.

## References

- [1] CCIR Study Group 7/A, Document 7/A TEMP 15 - Proposed amendment to Report 363-7, Geneva, 1991.
- [2] D. Jackson, R. J. Douglas, "A telephone based time dissemination system," *Proc. 18th PTTI Meeting*, USA, Dec. 1986, p. 541–552.
- [3] J. Levine, M. Weiss, D. D. Davis, D. W. Allan, D. B. Sullivan, "The NIST digital time service," *Proc. 21st PTTI Meeting*, USA, Nov. 1989, p. 181–190.
- [4] D. Kirchner, "Genauere Zeit für rechner über telephonmodems," *Proc. Mikroelektronik 89*, Springer-Verlag, 1989, p. 103–108.
- [5] E. Brännström, "European Computer Time Service," *Proc. 5th European Frequency and Time Forum*, France, 1991, p. 284–287.
- [6] F. Caviglia, *Prestazioni della rete analogica mista*, CSELT internal report, May 1992.
- [7] M. Malcangi, *Il modem, teoria, funzionamento e applicazioni*, Jackson, 1989.
- [8] S. Leschiutta, "Long term accuracy of time comparisons via TV signals along radio links," *IEEE Trans. on Instr. and Meas.*, vol. IM-22 no. 1, p. 84–87, March 1973.
- [9] E. Rubiola, "Short distance frequency distribution systems," *Proc. 2-nd European Frequency and Time Forum*, Switzerland, 1988, p. 263–270.

## QUESTIONS AND ANSWERS

**M. Weiss, NIST:** Do you have plans to implement a service that allows you to adjust the transmission of the on time marker?

**F. Cordara, Istituto Elettrotecnico Nazionale Galileo Ferraris:** Yes; we also have this plan for the end of 1993. The most widespread service is truly devoted to the one way users which seems to be the most in our account. We have several inquiries about this kind of service in the 1 second to 0.1 second region.

**M. Weiss:** So we have jumped from the nanosecond time transfer to the 1 second time transfer. Apparently as you get less accurate there are a lot more users.